Masters Theses

Student Theses and Dissertations

1954

Determination of the thermal conductivity of sodium chloride at elevated temperatures

Harold Robert Weisbrod

Follow this and additional works at: https://scholarsmine.mst.edu/masters_theses



Part of the [Physics Commons](#)

Department:

Recommended Citation

Weisbrod, Harold Robert, "Determination of the thermal conductivity of sodium chloride at elevated temperatures" (1954). *Masters Theses*. 2604.

https://scholarsmine.mst.edu/masters_theses/2604

This thesis is brought to you by Scholars' Mine, a service of the Missouri S&T Library and Learning Resources. This work is protected by U. S. Copyright Law. Unauthorized use including reproduction for redistribution requires the permission of the copyright holder. For more information, please contact scholarsmine@mst.edu.

DETERMINATION OF THE THERMAL CONDUCTIVITY OF
SODIUM CHLORIDE AT ELEVATED TEMPERATURES

by

Harold Robert Weisbrod

A

THESIS

submitted to the faculty of the
SCHOOL OF MINES AND METALLURGY OF THE UNIVERSITY OF MISSOURI
in partial fulfillment of the work required for the

Degree of

MASTER OF SCIENCE, PHYSICS MAJOR

Rolla, Missouri

1954

Approved by William H. Bessey
Associate Professor of Physics

ACKNOWLEDGMENTS

The author wishes to express his appreciation to Dr. W. Bessey, Associate Professor of Physics at the Missouri School of Mines and Metallurgy, for his valuable suggestions and guidance throughout this investigation.

Acknowledgment is given to the Departments of Ceramic and Metallurgical Engineering for their freely given advice and materials.

Sincere gratitude is extended to The Research Corporation for their part in making this investigation possible.

TABLE OF CONTENTS

	Page
Acknowledgments.....	11
List of illustrations.....	1v
List of tables.....	v
Introduction.....	1
Review of literature.....	3
Method of the experiment.....	6
Description of the apparatus.....	12
Special considerations and techniques.....	19
Experimental procedure.....	25
Calculations.....	27
Experimental error.....	29
Conclusion.....	35
Summary.....	36
Bibliography.....	37
Vita.....	38

LIST OF ILLUSTRATIONS

Figure	Page
1. Various methods for measuring thermal conductivity in the steady state.....	10
2. Section of assembled apparatus.....	11
3. Schematic of thermocouple circuits....	14
4. Power circuit.....	17
5. Compared results of experimentally determined thermal conductivity of sodium chloride.....	34

LIST OF TABLES

Table No.	Page
1. Thermal conductivity of sodium chloride.....	33

INTRODUCTION

The temperature dependence of heat flow through single ionic crystals is explained by various theories of the solid state. Debye¹ examined the complicated problem of anharmonic coupling of vibrating phonons in cubic lattice structures. Sometime later, Peierls² published work of a similar nature, but more rigorous. They both show that thermal conductivity is proportional to $\frac{1}{T}$ at high temperatures. More recently, Pomeranchuk³ carried out calculations using a fourth degree term in the interaction potential. His results indicated a possible mixed type thermal conductivity proportional to $\frac{1}{T}$ and $\frac{1}{T^{3/2}}$, depending upon the anisotropy and dispersion present. Whether this theory or that shall gain favor depends largely upon its agreement with reliable experimental results.

At the present time, experimental results show a fairly credible thermal conductivity temperature relation between the freezing and boiling point of water, but little data has been taken at temperatures approaching the melting points of various alkaline-halide crystals.

-
- (1) Debye, P., Vortrage uber die kinetische Theorie etc., by M. Planck et al., Teubner, Leipzig, p.46, 1914.
 - (2) Peierls, R., Zur Kinetischen Theorie der Wärmeleitung in Kristallen, Ann. Phys. (Leipzig) Vol.3, pp.1055-1101, (1929).
 - (3) Pomeranchuk, On the Thermal Conductivity of Dielectrics at the Temperature Higher than the Debye Temperature, Journal of Physics, Moscow, Vol.4, pp.259-268, (1941).

The purpose of this research is to investigate possible methods of determining the thermal conductivity of small poorly conducting samples at elevated temperatures, and, further, to assemble a suitable apparatus, followed by measurement of thermal conductivity of one or more cubic lattice samples.

Basic requirements of the apparatus are few. It is first required that the measurement of thermal conductivity be made over a considerable range of temperature. It is also preferred that the basic apparatus be placed in a vacuum where undesirable heat flow by convection is eliminated and air corrodible samples are preserved.

The apparatus must use only the smallest samples from which accurate results may be obtained. The thermal conductivity temperature relation is not linear, so only small temperature intervals may be used.

REVIEW OF LITERATURE

Many early experimenters chose the readily available natural halite (NaCl) crystals for their study of heat flow through ionic structures. Prior to 1900, conductivities of sodium chloride were reported by Tuckschmidt⁴(1883) and by Lees⁵(1892). Each reported for a single temperature. In 1911, Eucken⁶ reported conductivities at four temperatures, the lowest 83° K., the highest 370° K. Later, certain controversies rose regarding the precise values of the conductivities reported by Eucken. This may be explained by the variation in the individual structures of the samples tested. Eucken and Kuhn⁷ have shown that for single crystals of high purity, artificially grown from solution or melt, conductivities may range 50% above those obtained from natural halite. Thus, it seems certain that precise values of thermal conductivities have little intrinsic value, yet they must be known of a given sample in order to formulate a rather general conductivity temperature relation.

Values for the thermal conductivity of sodium chloride

-
- (4) Tuckschmidt, Ann. Phys. Beibl., Vol.7, p.490, (1884).
(5) Lees, C. H., On the Thermal Conductivities of Crystals and other Bad Conductors, Phil. Trans. pp.481-509, 1892.
(6) Eucken, A., Ann. Phys. (Leipzig) Vol.32, p.185, (1911).
(7) Eucken, A., & Kuhn, G., Zs. f. phys. Chem., Vol.134, p.193, (1928).

from 273°K. to 673°K. were published by Birch and Clark⁸ in 1940. Their method and techniques do indeed suggest a high degree of reliability. Consequently, they are of considerable interest to an experimenter with a similar problem. Their apparatus provides careful compensation for heat interchange by radiation, a problem of greatly increased magnitude as operating temperatures are forced upward. This is perhaps best illustrated by the Stefan-Boltzmann law with a statement to the effect that the total emissive power of a black body is proportional to the fourth power of its absolute temperature. With high temperature operating efficiency a criterion, consideration was given to the method of Knapp⁹. Knapp reports conductivities from 373°K. to 1090°K. for certain substances. His heat flow apparatus lacked the necessary vacuum environment for working at high temperature with corrodible samples.

Investigation of thermal conductivity measurements of metals at high temperatures was of value. A study of the ap-

(8) Birch, Francis, & Clark, Harry, The Thermal Conductivity of Rocks and Its Dependence upon Temperature and Composition, American Journal of Science, Vol.38, pp.529-558, (1940).

(9) Knapp, W. J., Thermal Conductivity of Nonmetallic Single Crystals, The Journal of the American Ceramic Society, Vol.26, No.2, (1943).

paratus and measurements on iron by Armstrong and Dauphinee¹⁰ reveals an excellent piece of work upon which many "relative" heat conduction experiments have been built.

(10) Armstrong, L. D., & Dauphinee, T. M., Thermal Conductivity of Metals at High Temperatures, Canadian Journal of Research, Vol.25, pp.357-374, (1947).

METHOD OF THE EXPERIMENT

Two very general schemes for thermal conductivity determination are usually recognized. The dynamic or time dependent scheme considers change in temperature distribution as a function of time. Other than dynamic are the time independent or steady state methods which show no change in temperature distribution.

Granting that boundary conditions can be met, the Fourier heat equation

$$\frac{\partial \theta}{\partial x} = \frac{K}{\rho C_v} \nabla^2 \theta$$

may be applied. Here θ is the temperature, $\frac{K}{\rho C_v}$ defines the diffusivity where K is the thermal conductivity, ρ the density, and C_v the specific heat at constant volume. Boundary conditions are simplified by arranging the experiment to allow only one dimensional axial heat flow. A typical dynamic system is illustrated by the method of Angstrom.¹¹ He periodically passed steam and cold water over the short central part of a long bar. After a time the temperature at each point of the bar became periodic. Temperatures were read every minute at intervals of 5 cm. along the bar.

(11) Angstrom, A. G., Ann. Phys., Vol.114, p.513, (1861).

Due to the loss of heat from the bar by means other than hereby accounted for, the solution becomes too complicated for practical use. In general this is true of most dynamic methods.

The steady state methods favored by one dimensional, time independent, axial flow follow a reduced equation

$$\frac{d^2\theta}{dx^2} = 0 .$$

Integrating once yields

$$\frac{d\theta}{dx} = \alpha ,$$

which states that the change in temperature across a space interval dx is equal to a constant. Going from the derivative to the incremental form, the equation becomes

$$\alpha = \frac{\theta_2 - \theta_1}{x} .$$

Let the constant α be equal to the heat flowing perpendicularly across unit area. The Fourier heat equation in one dimension takes the form

$$\dot{q} = \kappa \frac{A}{x} (\theta_2 - \theta_1) ,$$

where the constant of proportionality κ is clearly the thermal conductivity given by

$$\kappa = \frac{x}{A} \frac{\dot{q}}{(\theta_2 - \theta_1)} .$$

Consequently, in the steady state experiment, satisfactory measurement of the quantities in the right hand member of the above equation is the only requirement of a reliable thermal conductivity determination. The steady state scheme was therefore favorably accepted as the general method of this experiment.

Two specific modes of steady state method are presented. The mode of "absolute" determination is characterized by generation of a measurable dq within a source, passing the known quantity of heat through the sample whereafter it flows into a constant temperature sink. The temperature gradient in the sample, the sample dimensions and the dq supplied provide all the necessary information for the determination.

The mode of "relative" determination bases its success upon the measurement of temperature gradients in a sample and in a calibrated reference material linearly coupled such that the same quantity of heat flows through each from the source at one end to the sink at the other. This is perhaps better seen from Figure I.

Until recently no reference materials having calibrated conductivities in the range approaching 1000°K . were available. Knapp's¹² use of 18-8 stainless steel and other experimenter's use of Corning's pyrex No. 7740 are of special interest. Armstrong and Dauphinee¹³ have calibrated a readily obtainable material, Armco iron. Their determination of thermal conductivity over the range 0° to 800°C . with an indicated absolute error of less than two percent and a relative error of much less than one percent provides a valuable

(12) Knapp, op. cit., p. 4

(13) Armstrong and Dauphinee, op. cit., p. 5

standard for "relative" methods.

A number of limitations immediately appear in the design of apparatus for the relative method. For best results the thermal conductivity of the sample should be approximately the same as that of the reference standard. The geometry may be improved by choosing the lengths of the sample and the reference standard to provide an approximately equal temperature drop across each. Thus, to measure the thermal conductivity of a one centimeter long sodium chloride crystal would require an Armco iron standard approximately fifteen centimeters in length. Objection to extended length is based on the increased thermal radiation problem so introduced. The use of non-metallic standard such as pyrex or quartz was excluded due to the former's low fusion point and the latter's uncertain calibration.

The "absolute" method is characterized by independence from all pre-calibrated standards. For this reason, and others mentioned above, the steady state "absolute" method for measuring thermal conductivity was chosen for this experiment.

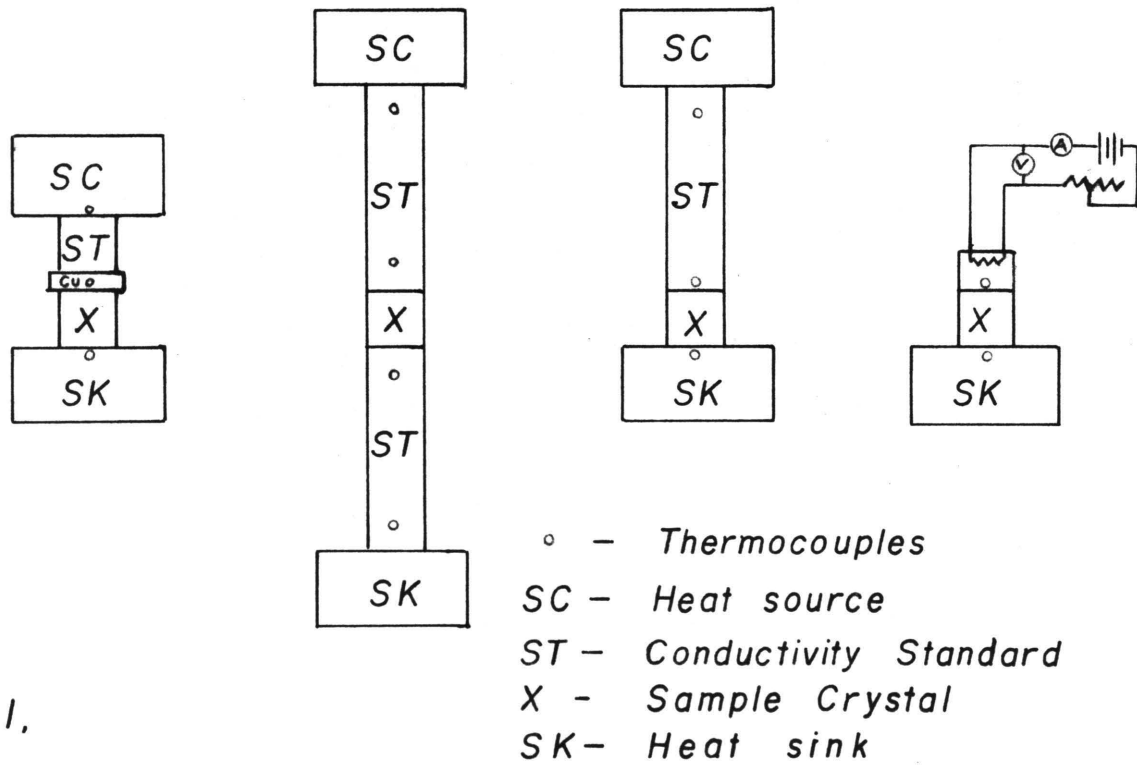
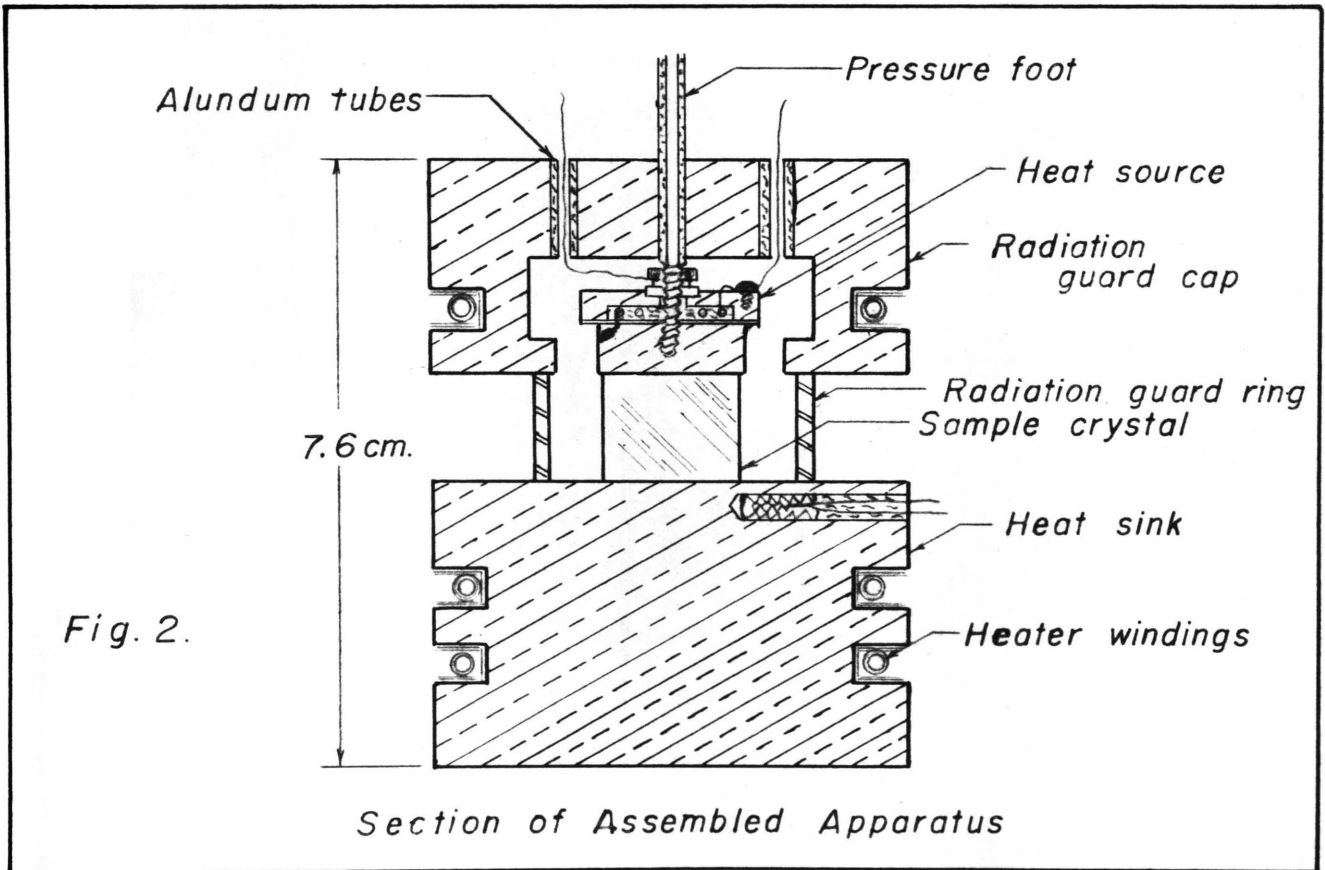

Fig. 1.

Schematic of various methods for measuring thermal conductivity in the steady state.



DESCRIPTION OF THE APPARATUS

A cross-sectional view of the apparatus is shown in Fig. 2. The heat sink is a solid copper cylinder 5 cm. in diameter. Sink heater windings are helically wound of 28 gauge Chromel C. They are insulated from machined grooves in the sink by sheet mica strips. The faces of the sink are ground flat.

The heat source winding is of 32 gauge resistance wire helically wound and imbedded in ceramic cement. Its 14 ohm resistance permits up to seven watts of source heating. The pressure foot is an alundum tube of 0.125" O.D. which passes through a close fitting hole in the guard cap where it applies the necessary downward force to the heat source. Alundum tubes peened into holes in the roof of the guard cap provide passageway for wires leading to the source.

The guard ring is cut from steel conduit tubing measuring 3 cm. outside diameter and 0.185 cm. wall thickness. Guard ring ends are ground flat and polished.

Excellent melt grown crystals classed as optical windows were supplied by Harshaw Chemical Co. The sodium chloride sample chosen is a right circular cylinder measuring approximately 1.2 centimeters along the axis of heat flow and 1.5 centimeters in diameter. Crystals of equal diameter but of any length may be substituted by simply replacing the guard ring with another of length matching the crystal.

Vacuum Connections

The heat flow apparatus is placed on a porcelain stand resting on the face of a 16" diameter pump plate. A 14" diameter pyrex bell jar completes the vacuum enclosure. The bell jar is sealed to the pump plate by application of a hot mixture of beeswax and rosin applied with a medicine dropper.

Below the pump plate is the vacuum and electrical lead receptical chamber. All electrical leads pass through the evacuation hole at the center of the base plate into the receptical chamber. The receptical chamber consists of a cylindrical brass tube 3" in diameter, 5" long, and flanged on either end. The flange bolted to the pump plate is grooved to accommodate a rubber ring seal. Attached to the lower flange are two bakelite plates drilled to take all thermocouple and lead wires into the vacuum. Small rubber discs were placed between the bakelite plates, and through the center of each rubber disc passes a lead wire. Compression of the bakelite plates by means of cap screws presses the rubber about each wire effecting the seal. A steel washer surrounding each rubber disc limits the lateral expansion of the disc. With this seal pressures below 0.1 micron may consistently be held.

Thermocouple Circuits

Chromel-alumel thermocouples are the exclusive heat

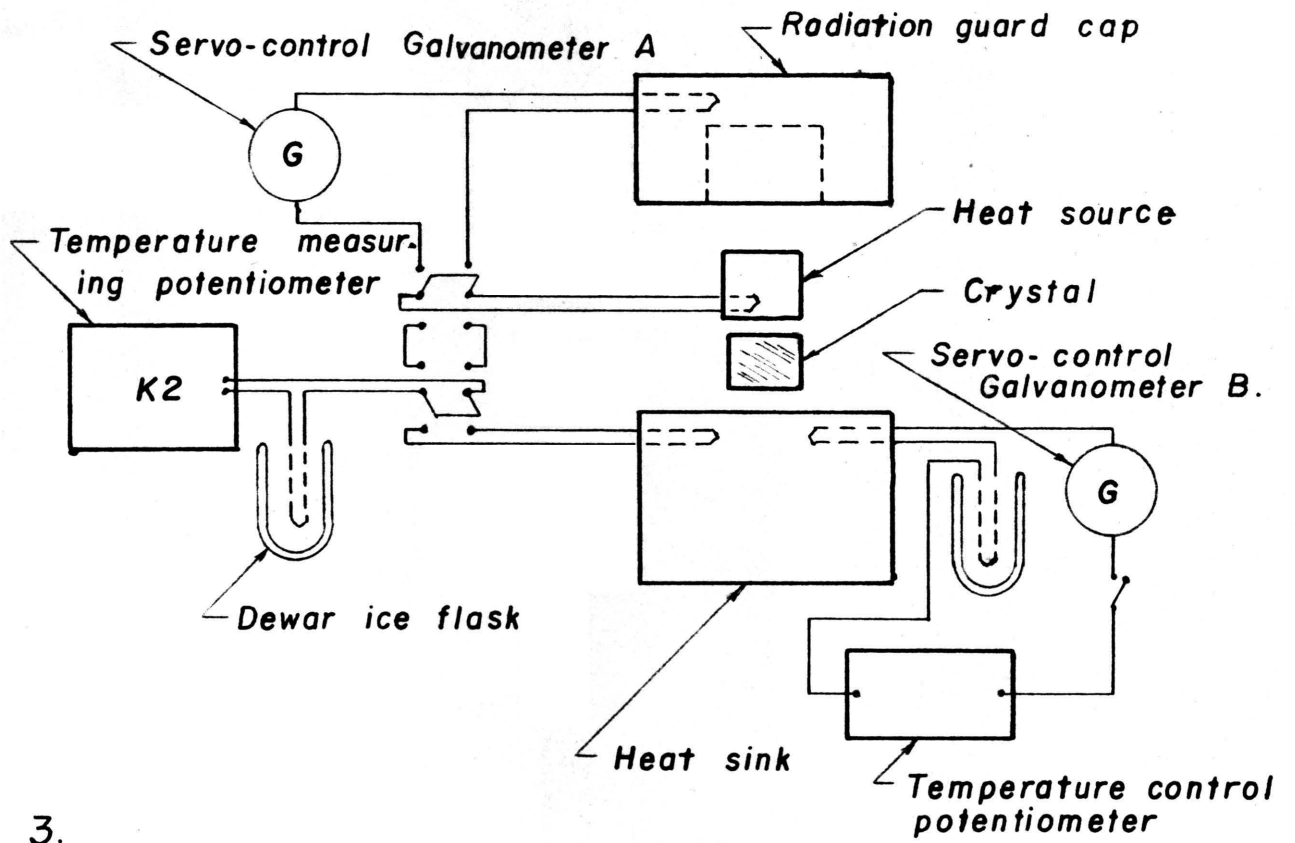

Fig. 3.

Schematic of Thermocouple Circuits

sensing elements for temperature measurement and control. To illustrate the need for special control consider a typical operating level with the sink at 100°C . The power setting of the source may be set at 0.3 watts giving a source temperature elevation of about 6°C . The need to operate the radiation guard cap at the same temperature as the source (106°C .) is obvious. Heat then flows from the guard cap through the guard ring into the sink. The full temperature drop (6°C .) then appears across the guard ring just as it does across the crystal. With the temperature gradient along the guard ring approximating that along the crystal, no net lateral radiant heat flow should be present.

In general a large part of the heat lost by the entire flow apparatus is radiated into the bell jar and its surroundings. Thus, power requirements to the sink and guard cap depend on the mean temperature of the surroundings. The power setting of the sink depends upon no less than four variables; namely, the operating temperature, the mean temperature of the surroundings, the power setting of the source, and the line voltage of the power supply. The same is true of the power setting for the guard cap. Simultaneous juggling of power settings to achieve the delicate balance of temperatures required for steady state operation has been done successfully by a number of experimenters. However, the use of thyatron servo-controlled power circuits for sink and guard cap heating has resulted in some saving of time. The thermocouple circuit diagram of figure 3 illus-

trates how switching is done to measure all necessary temperatures with the Leeds & Northrup type K2 potentiometer.

The source has but one thermocouple for reasons to be mentioned later. Consequently, when the source temperature is measured, the control signal to galvanometer A is temporarily open. This is not serious, however, for control signals are set to operate near the zero level for average power delivery.

Control Circuits

Figure 4 illustrates the temperature regulating circuit as described by Strong¹⁴. Modifications to fit the needs of the circuit are few.

Light from an auto headlight bulb is condensed by lenses and set to bear upon a wedge-shaped slit which serves as the object of the optical system. A ten diopter lens sends a convergent beam to the galvanometer mirror. After reflection, the beam continues to converge until it is finally focused in the plane of the photoelectric cell. The wedge-shaped image provides a near linear correcting influence which approaches zero as the error in temperature diminishes. It can be seen from the thyatron phase shift circuit that most of the heater load may be supplied by alternating current through shunt resistor R_2 . Thus, only a

(14) Strong, John, *Procedures in Experimental Physics*, N. Y., Prentice Hall, p.448, 1938.

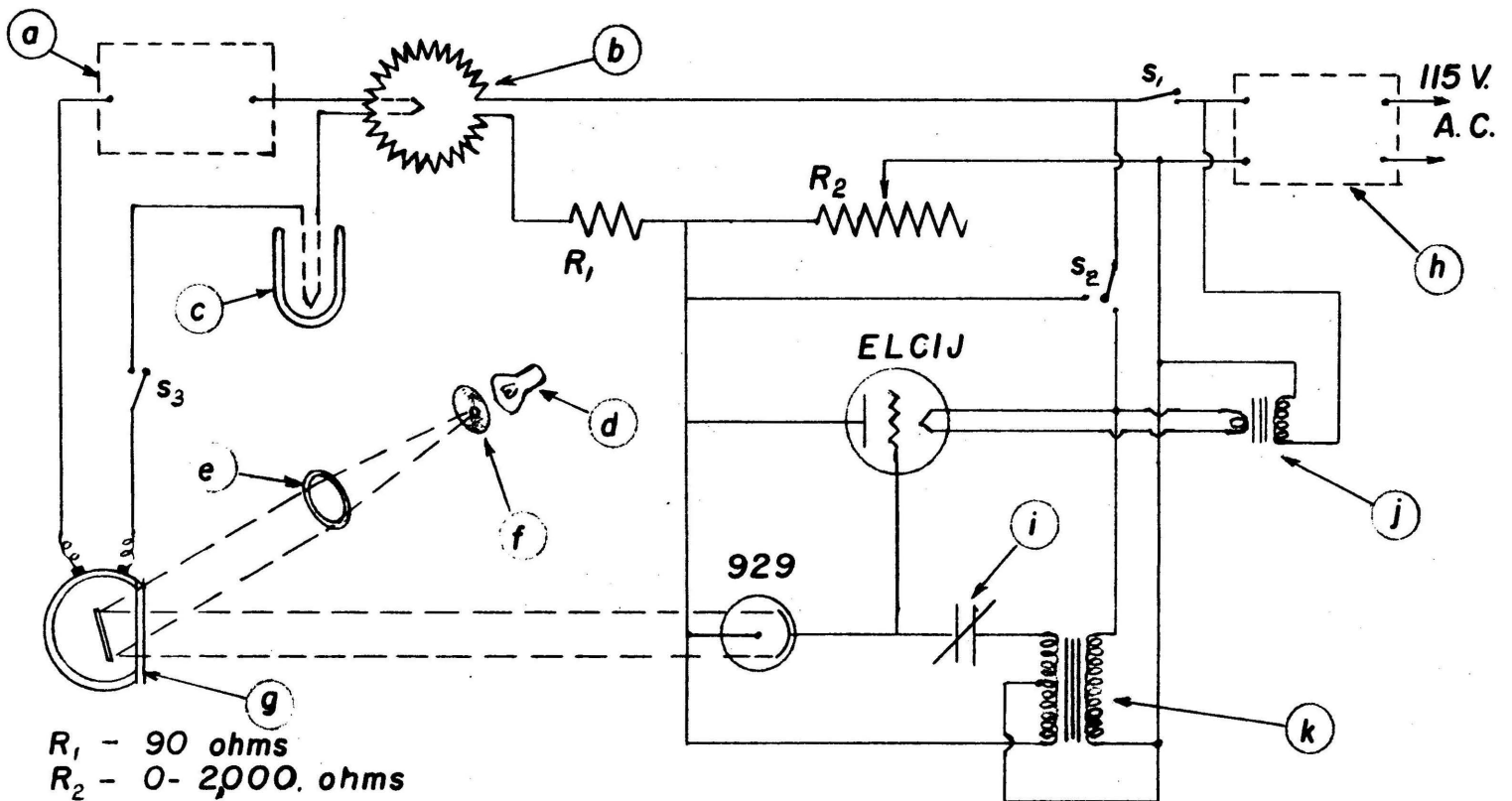

R_1 - 90 ohms

R_2 - 0-2000. ohms

a - Control potentiometer

b - Heater Windings

c - Dewar ice flask

d - Auto headlight bulb

e - Lens

f - Reticle

g - Control galvanometer

h - Voltage regulator

i - 250 μ Hf

j - 2.5 volt filament supply

k - Phase shifting transformer

slight correction current need be supplied by the servo system. Hunting is eliminated by carefully adjusting the shunt resistor to pass most of the heating current.

SPECIAL CONSIDERATIONS AND TECHNIQUES

A. Thermal contacts

In order to assure rectilinear flow of heat through the crystal, excellent contact must be assured at the crystal interfaces. Although the crystal samples have optically finished surfaces, the copper source and sink faces can not be polished optically flat. Had all interface surfaces been finished optically flat, rectilinear heat flow across the faces would still not be assured. Experimenters have solved this problem at lower temperatures by placing a drop of pump oil or glycerin at the interfaces. Since these fluids have significant vapor pressures above 150°C., their use above this range is not practicable. Films of metal foil at the interface subsequently brought to the fusion point produce satisfactory thermal contact if both surfaces are wetted by the intermediate metal. The present conductivity measurements have been made with tin foil at the interface. Apparently tin does not actually wet the sodium chloride surface, but no particularly elegant solution to this problem has come into view.

B. Thermocouples

The use of pre-calibrated 28 gauge chromel P and alumel thermocouple wire has resulted in a considerable saving of time. Junctions were made by first cleaning about a cen-

timeter length at the end of each wire, twisting the ends together, followed by silver-soldering, or welding with the aid of borax flux. The heat sink and guard cap thermocouples were set into drillings in the end of 0.125" diameter, 0.375" long copper rods. The rods were then soft-soldered into drilled holes at the necessary positions in the apparatus.

In the heat source the welded junction was placed in a small bore drilling and then set with a 2-56 cap screw. In order to reduce the heat taken to or from the source through the thermocouple junction, the leads were wrapped halfway around the source, and then taken out through the insulated holes in the guard cap.

Thermocouple leads leaving the heat flow apparatus are attached to terminal strips within the vacuum. From the terminal strips to the vacuum exit they are insulated with polystyrene tubing. Outside the vacuum the leads go either to the reference junction in the dewar flask, or directly to an insulated oil bath where they are joined with copper. All junctions with copper are made within the oil bath.

Once joined to copper, the remainder of the critical circuit with the exception of the K-2 potentiometer is composed of copper. A thermal e.m.f. may be set up in the potentiometer but it has been found to remain essentially constant during the thirty seconds or less required to

measure the source and the sink temperatures.

When operating at the proposed high temperatures, thermocouples may become contaminated with deposits of evaporated metal. Armstrong and Dauphinee¹⁵ have found copper to be an unsatisfactory metal for large components of their apparatus due to this effect. Their solution was to install a solid gold sink, guard cap, and other parts. A proposal to use heavy gold plating upon copper has been suggested for use if this condition becomes observable in the present system.

C. Electrical Shielding

Analysis of all electrical circuits for electrostatic, electromagnetic, and current leakage effects was carried out with rigor. A major problem appeared in the need to completely isolate power and sensing circuits. The guard cap and the sink are each heated by separate thyratron power circuits which supply up to sixty volts alternating current with an added half wave direct current component. Thus, power leads carrying sixty volts alternating current are adjacent to thermocouple leads carrying potentials which need be measured accurately to within one microvolt. Segregation of power and thermocouple leads was carried out with considerable care. Their interaction was checked by taking precise readings of temperatures, cutting all power switches and reading temperatures again. The latest circuits showed

(15) Armstrong & Dauphinee, op. cit., p.5

no measurable interaction.

Electromagnetic effects are prevented by using helical heater windings looped into a near perfect toroid. Toroidal windings have no external field.

The two thyatron circuits could not be supplied from the same line. Isolation was carried out by installing individual voltage regulating transformers of the type supplied by Sola.

The light amplifier was located in a near-by photographic dark room. Leads from the photoelectric cell to the thyatron power supply had to be widely separated in order to reduce their electrostatic capacitance.

D. Thermal Shielding and Lead Losses

It can be shown that thermal losses by radiation will be held at a minimum if temperatures are completely matched throughout the critical heat flow area. Calculations show that net heat exchange between various surfaces in an enclosure are dependent upon temperature, size, and emissivity. The need for closely matched guard cap and heat source temperatures can be seen from inspection of the Stefan-Boltzman radiation equation

$$Q = \sigma \epsilon A (\theta_1^4 - \theta_2^4)$$

Q represents the heat flow, σ the radiation constant, ϵ the emissivity, A the area, and θ the temperature. The meaning of the parenthetical expression is obvious. The power four is theoretical and approximate. Actually, em-

pirical values for σ and the power of θ vary with material and temperature. The above equation illustrates the greater need for temperature matching with higher absolute temperature. The present thyatron servo-mechanism can be adjusted to match guard cap and heat source temperatures to within a few tenths of a degree centigrade.

Six lead wires are attached to the heat source. Heat flowing from the source along these wires cannot be sensibly distinguished from heat flowing down the crystal. Thus, an error creeps into the thermal conductivity measurement.

Of the six lead wires, two are thermocouple leads of 0.0125" diameter. Their total length inside the isothermal guard cap exceeds 4 cm. Four leads are of 0.005" diameter chromel resistance wire. Two of these leads supply power to the source and other two are used to measure voltage drop across the source resistance. Advantageously, chromel offers much resistance thermally, so losses by this means can be held quite low. Further details in this connection are given in the discussion on error.

The question has risen as to how radiant energy transfer through the crystal (which is transparent to infra-red) can be separated from ordinary conduction. It can be shown that at 1000°K. radiant energy transfer from source to sink is approximately equal to the estimated conduction. No method of separating the two modes of energy transfer has thus far been reported in the available literature. It is

hoped that work along this line can be done with the present apparatus.

No thermal shielding surrounding the heat flow apparatus has been used below 125°C. At higher temperatures power requirements of the sink and guard cap become large. Temperature gradients caused by excessive surface radiation disturb the equilibrium pattern of the flow assembly. Some form of radiation shielding about the entire flow assembly must be provided.

EXPERIMENTAL PROCEDURE

Once initial preparations for a conductivity measurement have been completed, and a vacuum below one micron within the bell jar is assured, the heat flow apparatus may be rapidly brought to the proposed operating temperature by alternating current heating. The millivolt equivalent of operating temperature is set on the dials of control potentiometer B (Fig. 3). Thus, when the wedge-shaped light beam reflected from control galvanometer B crosses over its respective photoelectric cell, the time to do the necessary switching to servo-control is at hand. Meanwhile the guard cap may be brought to temperature in an identical manner with the exception that its circuit reasonably includes no control potentiometer. Thus, when the light beam reflected from control galvanometer A is incident upon photoelectric cell A, the guard cap and the heat source are conveniently at the same temperature. Subsequent switching to servo-control, followed by several refining adjustments of power circuit shunt resistors will cause the system to settle into a placid steady temperature state.

Once consecutive readings of source and sink temperatures do not vary by more than a pre-determined amount during a certain minimum time interval, data may be recorded. Differences in steady state temperatures of the source and sink measured while no source heating is applied result in an indication of "background". Measurements of temperatures

taken at three different source power settings, carefully allowing equilibrium to become established at each power will provide not only multiple data for conductivity computation, but much valuable information concerning the performance and reliability of the system.

CALCULATIONS

The equation of thermal conductivity as given earlier in the report is

$$K = \frac{\chi}{A} \frac{Sg}{(\theta_2 - \theta_1)} .$$

In the C.G.S. system K has the units

$$\frac{\text{Calories}}{\text{Cm. Sec. } ^\circ\text{C}} ,$$

where Sg is in calories/sec.

Use of electrical heating suggests Sg be expressed in watts.

Thus, the units of K are simply

$$\frac{\text{Watts}}{\text{Cm. } ^\circ\text{C}} ,$$

which differs from C.G.S. units by a factor J.

If V and I are voltmeter and ammeter readings of source power, wattage is given by

$$W = V \left(I - \frac{V}{r_1} \right) \left(1 + \frac{r_2}{r_1} \right) ,$$

r_1 voltmeter resistance, r_2 resistance of voltmeter leads. Measuring V with a potentiometer, or with a voltmeter of very high internal resistance will justify the reduced form

$$W = IV .$$

Thermal expansion of the crystal will effect the term

$$\frac{\chi}{A} .$$

Properly allowing for expansion the ratio is

$$\frac{\chi}{A} = \frac{\chi_0}{A_0} \frac{(1 + \alpha\theta)}{(1 + 2\alpha\theta)} ,$$

where χ_0 and A_0 are computed from sample measurements taken at 0°C ., and α is the mean linear coefficient of expansion.

In the main the above ratio reduces to

$$\frac{\chi}{A} = \frac{\chi_0}{A_0} \frac{1}{(1 + \alpha\theta)} .$$

The average thermal conductivity in the range from θ_1 to θ_2 is given by the formula

$$K_m = \frac{x_0}{A_0} \frac{1}{(1 + \alpha \theta)} \frac{I V}{(\theta_2 - \theta_1)}$$

and the temperature for which K_m is reported is

$$\theta = \frac{\theta_2 + \theta_1}{2} .$$

EXPERIMENTAL ERROR

Consideration is given to the following sources of error:

1. Errors in measurement of sample dimensions.
2. Errors in measurement of power input.
3. Errors due to the apparatus not being at equilibrium.
4. Heat loss from the source and sample by radiation.
5. Heat loss by conduction along leads and ceramic pressure foot.
6. Errors due to uncertain surface coupling at the crystal interfaces.
7. Errors due to non-linear flow in the sample.
8. Errors in the measurement of the temperature interval.

1. The ratio $\frac{\lambda}{A}$ can be computed from precision measurements to within 0.01%. The thermal expansion of sodium chloride is nearly a constant over the temperature range under investigation, so its effect is satisfactorily accounted for in the conductivity formula. If not considered, the consequent error in thermal conductivity would approach 0.5% per 100°C. temperature elevation.

2. If a voltmeter is used in the power measurement, the probable error in wattage is about 1.2%. Use of a potentiometer to measure the voltage reduces the probable error to less than 0.75%.

3. It can be shown that drift in the sink temperature of 0.005°C. per minute will result in approximately 1.0% error in the conductivity measurement. Cyclic drifting or "hunting" can be eliminated by careful adjustment of the

servo-mechanism components. A near constant drift may come about by falling voltage in the control potentiometer A reference battery. Whatever the drift, it must be less than 0.005°C . per minute for a period of 15 minutes before readings are acceptable.

4. Calculations show that if guard cap and heat source temperatures differ by 0.1°C ., the error introduced at 1000°K . will be approximately 10.0%. This is calculated from Stefan's law for radiant energy transfer across surfaces at nearly equal temperatures. The error decreases as the third power of the absolute temperature. At 500°K ., this error would be less than 1.0% of the total heat input. Calculations are based on a source-sink temperature difference of 6°C ., and a thermal conductivity proportional to $\frac{1}{T}$.

5. Errors due to heat transfer away from the source along the pressure foot and lead wires vary with temperatures of radiant surfaces surrounding the guard cap. These errors are approximately proportional to the temperature differences, and increase greatly with the absolute temperature. Conduction along the lead wires can be nearly eliminated by cementing the wires to the guard cap. Conduction along the pressure foot is a function of the area of the foot contacting the heat source. Consequently, this area is kept small. Conservative calculations of the total error due to the sources mentioned in this paragraph place

it at 3% when the operating temperature is 150°C., and the surroundings average 30°C.

Radiation shielding surrounding the entire apparatus will greatly reduce these errors at elevated temperatures.

6. The surfaces of the crystal in contact with the source and the sink present a certain finite discontinuity toward heat flow. The magnitude of the discontinuity cannot be found by direct computation, but use of a variety of interface substances, holding other conditions equal, produce a means of estimating the magnitude of the effect. In one instance thermal conductivity averaged 5% higher when an interface substance (silicone grease) capable of wetting both surfaces was used.

7. Non-linear heat flow in the sample is chiefly caused by poor thermal contact at the interface boundaries. Other causes are imperfections in the crystal, and radiation from the surface. Since imperfections are present in all crystals, conductivity measurements of several apparently identical samples should reveal the extent of abnormalities. Non-linearity due to radiation effects increases at elevated temperatures.

8. Errors in the measurement of temperature interval may be due to parasitic e.m.f.'s, faulty thermocouples, thermocouple installation, or potentiometer readings. All thermocouples were found to produce equal e.m.f.'s when measuring the temperature of a massive copper block in which

they were all imbedded. The largest error in measuring temperature interval arises from imperfect thermocouple installations. From measurements of background, error in temperature measurement has been estimated to be less than 5%.

RESULTS

Tabulated results listed in Table 1 are computed from the most recent and reliable data thus far obtained with the described apparatus. They are graphically compared with the published results of other observers in figure 5. From the logarithmic plot of figure 5 it can be clearly seen that thermal conductivity in the temperature range observed is proportional to neither $\frac{1}{T}$ nor $\frac{1}{T^{3/2}}$, but to something lying between them.

TABLE I
THERMAL CONDUCTIVITY OF SODIUM CHLORIDE

Date	Run No.	Source mv	Sink mv	ΔV μV	$\theta_2 - \theta_1$ (°C)	$\theta = \frac{\theta_2 + \theta_1}{2}$ (°C)	Amp.	Volts	K (Watts/cm.C°)
Feb.15	1	4.477	4.382	95	2.32	108.3	0.100	1.44	0.0416
	2	8.086	7.806	280	6.88	195.2	0.150	2.15	0.0316
Feb.18	1	7.296	7.097	199	4.88	176.2	0.134	1.89	0.0334
Feb.19	1	3.572	3.483	89	2.18	86.7	0.100	1.44	0.0434
	2	6.139	5.190	235	5.75	147.4	0.150	2.14	0.0367

Fig. 5

COMPARED RESULTS OF EXPERIMENTALLY DETERMINED
THERMAL CONDUCTIVITY OF SODIUM CHLORIDE

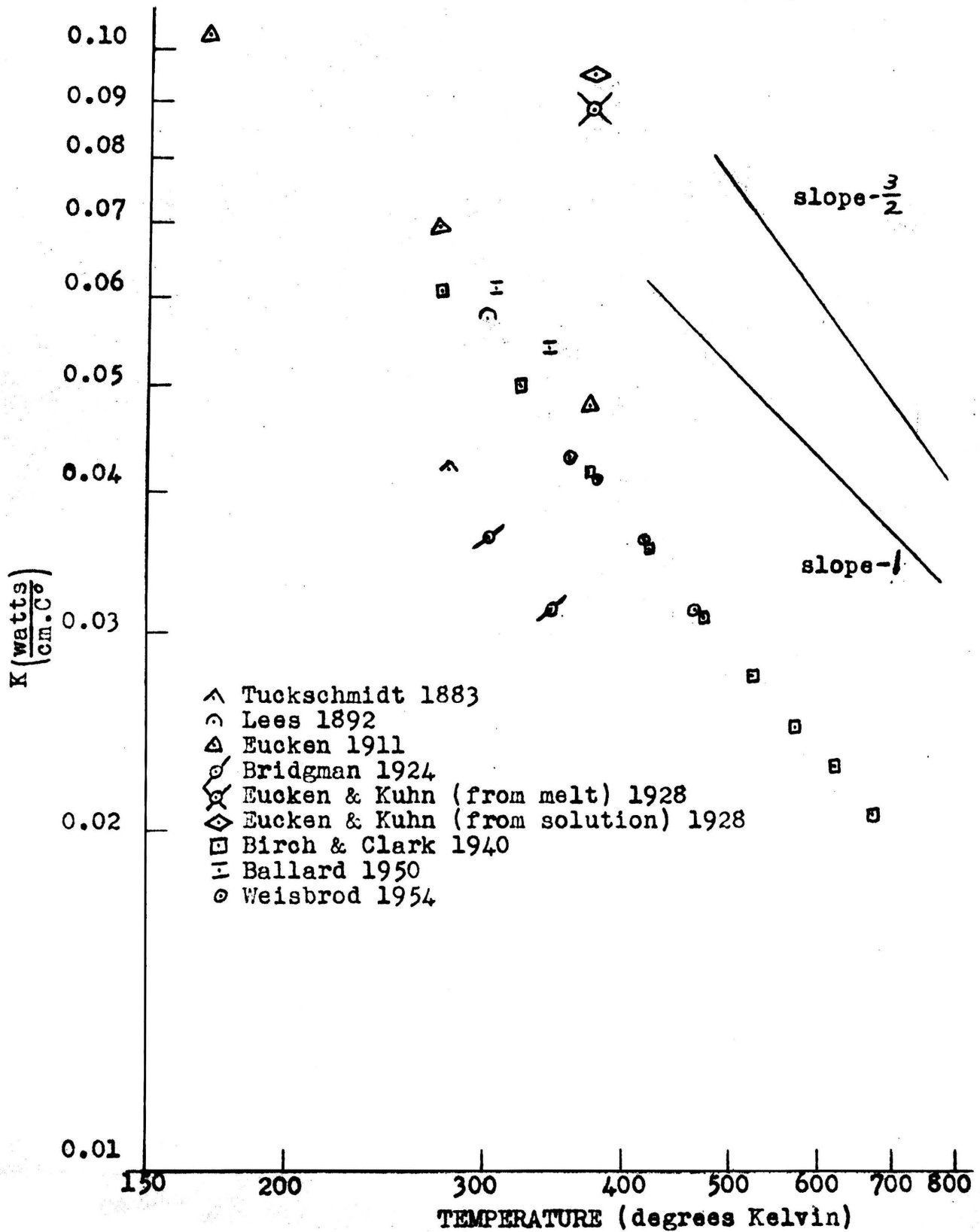

CONCLUSION

Description has been given of an apparatus capable of determining the thermal conductivity of small samples in the temperature range 340° to 460° K. With the installation of certain modifications this temperature range is expected to be extended far higher. Measurements on a sample of sodium chloride indicate a standard deviation from the mean of 1.6%. The results on sodium chloride fall between comparable determinations of other experimenters in the temperature range thus far investigated.

SUMMARY

It has been indicated that information on the temperature dependence of thermal conductivity in poorly conducting solids is sought for correlation with theory of the solid state. An apparatus for the measurement of thermal conductivity over an elevated temperature range has been assembled and operated. The method of measurement is based on the establishment of a steady state temperature gradient across a right cylindrical sample. The sample is sandwiched between a heat source of constant strength, and a heat sink of constant temperature. Suitable guards are installed for reduction of thermal losses by radiation. Electronic circuits aid in maintaining constant temperatures. With this arrangement, a number of thermal conductivity measurements were taken on a single crystal sample of sodium chloride in the temperature range 340° to 460° K. Measurements in the range thus far observed indicate a temperature dependence approximately coincidental with that found by Birch & Clark.¹⁶

(16) Birch, Francis, and Clark, Harry, op. cit., p. 4.

BIBLIOGRAPHY

- Angstrom, A. C. Ann. Phys. (Leipzig) Vol. 114, p. 513 (1861)
- Armstrong, L. D., and Dauphinee, T. M. Thermal Conductivity of Metals at High Temperatures. Canadian Journal of Research. Vol. 25, pp. 357-374 (1947)
- Ballard, S. S., and McCarthy, K. A., and Davis, W. C. Review of Scientific Instruments. Vol. 21, No. 11, pp. 905-907 (1950)
- Birch, Francis, and Clark, Harry. The Thermal Conductivity of Rocks and Its Dependence upon Temperature and Composition. American Journal of Science. Vol. 38, pp. 529-558 (1940)
- Bridgman, P. W. American Journal of Science. Vol. 7, p. 81 (1924)
- Debye, P. Vortrage uber die kinetische Theorie etc., by M. Planck et al. Teubner, Leipzig, 1914. p. 46.
- Eucken, A. Ann. Phys. (Leipzig) Vol. 32, p. 185 (1911)
- Eucken, A., and Kuhn, G. Zs. f. phys. Chem. Vol. 134, p. 193 (1928)
- Knapp, W. J. Thermal Conductivity of Nonmetallic Single Crystals. The Journal of the American Ceramic Society. Vol. 26, No. 2 (1943)
- Lees, C. H. On the Thermal Conductivities of Crystals and other Bad Conductors. Phil. Trans. pp. 481-509 (1892)
- Feierls, R. Zur Kinetischen Theorie der Warmeleitung in Kristallen. Ann. Phys. (Leipzig) Vol. 3, pp. 1055-1101 (1929)
- Pomeranchuk, I. On the Thermal Conductivity of Dielectrics at the Temperature Higher than the Debye Temperature. Journal of Physics. Moscow. Vol. 4, pp. 259-268 (1941)
- Strong, John. Procedures in Experimental Physics. N. Y., Prentice Hall, 1938. p. 448.
- Tuckschmidt. Ann. Phys. Beibl. Vol. 7, p. 490 (1884)

VITA

Harold Robert Weisbrod, son of Mr. and Mrs. Elmer Weisbrod, was born near Fenton, Iowa on February 12, 1921. Following graduation from Fenton high school in 1938, he farmed with his father for two years. He then took technical training in aircraft fabrication followed by employment in the aircraft industry in California until his entry into the armed forces. While serving thirty-nine months with the United States Army Air Force, he attained the rank of Sergeant as an airplane armorer gunner in the far-eastern war theater. In 1946, following military service, he was married to Miss Betty Ann Meyers of Fenton, Iowa. The same year, he attended Iowa State College. Employment in industry prevented continuation of formal education until 1949 when his study at Buena Vista College led to the degree Bachelor of Science in 1952. In the fall of the same year he entered Missouri School of Mines and Metallurgy as a graduate assistant in the Department of Physics. His second and third semesters were attended as a fellow of The Research Corporation.

The author is the father of two sons, Gregory Al, born in 1947, and Kirk Ryan, born in 1951.